

HENGSTLER



Technical Manual

Version 2.1
Item no. 2 543 048

RA 58-P
with SUCOnet - K1

© by HENGSTLER

The company HENGSTLER holds the copyright for this publication.

No part of this publication may be changed, expanded, reproduced or distributed to third parties in any form or by any means without the prior written permission of the company HENGSTLER.

HENGSTLER GmbH
Postfach 11 51
D -78 550 Aldingen GERMANY

Phone: [+49] 74 24 - 8 95 39
Fax: [+49] 74 24 - 8 93 70

Date of this edition: 25.02.1999

The HENGSTLER company reserves the right to make any technical changes and modifications necessary to improve its equipment.

Table of Contents

About this Manual	4
Abbreviations	4
1 Introduction	5
2 Safety and Operating Instructions	6
3 Setting Options	7
3.1 Code Course	7
3.2 Scaling	7
3.3 Zero Offset	9
4 Order of Transmission	10
4.1 Order of Parameter Input	11
4.2 Default Setting of the Parameters	11
5 Permanent Memory in the RA 58	12
6 Data Transmission	13
6.1 Handshake between Host and RA 58	13
6.2 Data Traffic via SUCOnet	13
6.3 Description of the Configuration Parameters (CP)	17
7 Hengstler G1-Protocol	21
7.1 Bit Encoding of the Address Word	21
7.2 Time Response G1-Protocol	21
8 Hardware Setting Options:	22
9 Initial Operation	23
10 Technical Data	25
11 Drawings	27
12 Order Code	28

HENGSTLER

About this Manual

This manual describes the absolute value transmitters RA 58 for SUCOnet connection.

The absolute shaft encoder RA 58 is a product used in industrial electronics. This manual is intended for people that have been trained in the field of electronics and electrical technology. It is expected that you have technical knowledge in the areas of electrical technology, microelectronics, computer installation and computer configuration.

The manual has been created with the utmost diligence. However, deficiencies cannot be excluded. Hengstler cannot be held liable for any error that may be contained in this publication and for any consequence arising thereof.

We welcome any remarks and comments from our users intended to improve this manual.

The term "number of measured increments" shall hereafter be the position before the electronic control determined by the transmitter. "Actual value" is the value that is transmitted to the host as converted value (after the electronic control as absolute position referring to the machine, e.g. in millimeters). The measuring unit for the actual value is "increments."

For setting the parameters of the RA 58, the SPC sends the individual configuration parameters (hereafter called "CP") to the RA 58.

The data format with which the data are sent to the RA 58 and with which the host receives the data from the RA 58, is described in the chapter „Data Traffic via SUCOnet,, on page 13.

Abbreviations

The following abbreviations are used in this manual:

NoT	=	Number of turns	AV	=	Actual value
NDI	=	Number desired increments	CP	=	Configuration parameter
NMI	=	Number measured increments	MIT	=	Measured increments per turn
INL	=	Instruction list	SCF	=	Scaling factor
Ccw	=	Counterclockwise	NoI	=	Number of increments
Cw	=	Clockwise	T	=	Turn
Dt	=	Data transmission			

1 Introduction

Absolute angle encoders provide an absolutely encoded value for each individual angle position. All these values are stored as a code pattern on one or several code discs. The code discs are scanned optoelectronically; the bit pattern obtained in this way are enhanced and delivered to a μ -controller for processing. After the processing, the values can be read via the SUCOnet interface.

The absolute angle encoder RA 58 resolves one transmitter turn into 1024 or 4096 measured increments (= 10/12 bits). In addition, the multiturn execution encodes 4096 turns (= 12 bits). This is an RA 58 transmitter range of 2^{12} measured increments in case of singleturn and 2^{24} measured increments in case of multiturn execution.

The result of 10/12 bits or 10/12 bits + 12 bits is encoded along with command and status bytes. Data output is binary and shown as a two's complement.

The angle encoder RA 58 can be purchased in different mechanical designs (see drawings).

The parameters for the angle encoder RA 58 can be set via the SUCOnet interface. This function permits the transmitter to be employed universally. This will save the host computer (e.g. PS3, PS306, PC with appropriate interface) a lot of computing time and trouble.

Parameters can be set for the following functions:

- Setting of the direction of rotation (code course)
- Electronic control
- Zero offset

For residual saving of the parameters, the RA 58 is equipped with an EEPROM. The parameters are automatically transmitted into the working storage when the device is turned on.

2 Safety and Operating Instructions

- The absolute shaft encoders of the series RA 58 are quality products constructed according to the recognized rules of electronic technology. Upon leaving the production plant, the devices were inspected to assure an impeccable state in regard to safety regulations. In order to maintain this state and to assure faultless operation, you should follow the technical specifications contained in this manual.
- Assembly and installation of electrical devices may only be performed by a person trained in electrics!
- The devices may only be used within the limits given in the technical data.
- You may not exceed the maximum operating voltages!
The devices have been constructed in accordance with the standard DIN EN 61010 part 1, class of protection III.
To avoid dangerous body currents, they have to be used with safety extra-low voltage (SELV) and located in an area with equipotential bonding.
- For protection, use an external fuse (see chapter Technical Data).
- Application: industrial processes and control.
Overvoltages at the connectors have to be limited to the values of overvoltage category II.
- Avoid any kind of shock to the case – in particular to the transmitter shaft – and avoid axial and radial overstress of the transmitter shaft.
- Maximum precision and serviceable life of the transmitters can only be guaranteed if an appropriate coupler plug and socket connection is used.
- The good EMV values only apply in connection with the cables and plugs supplied as standard. In case of shielded cables, the shield has to be connected to ground on both sides and on a large surface. The lines to the power supply should also be completely shielded. If this is not possible, use appropriate filters.
- The installation environment and the cabling have a profound influence on the EMV of the transmitter so that the installer has to insure the EMV of the entire unit (device).
- In areas that are electrostatically critical, make sure during installation that there is a good ESD protection for plug and cable to be connected.

3 Setting Options

3.1 Code Course

To adjust the code course of the RA 58 to the direction in which the machine moves, a parameter can be sent to the RA 58 which determines the counting direction of the transmitter (see chapt. 0, CP no. 06). Admissible values for the encoding of the actual value position are:

1. Counting upwards with shaft turning clockwise (=cw), facing the shaft.
2. Counting upwards with shaft turning counterclockwise (=ccw), facing the shaft.

Preset code course = cw

If the direction of rotation is changed, the new actual value is the two's complement of the old actual value.

3.2 Scaling

The RA 58 resolves a transmitter turn into 1024 or 4096 measured increments (= 10/12 bits). The number of turns is 4096 (= 12 bits). If you need different resolutions, this can be done with an "electronic control."

To use the electronic control, the transmitter needs data with which it can convert the measured increments read from the code disc into the desired actual value of the position (in increments) depending on the mechanical conditions of the unit.

The actual value transmitted by the transmitter is computed as follows:

Actual Value = Number of Increments x Scaling Factor

- Actual value (AV): position in "increments" transmitted by the transmitter to the host
- Number of increments (NoI): physical position of the transmitter disc in "number of measured increments"
- Scaling factor (SCF): multiplier for computing the actual value ($SCF \leq 1$).

There are 3 different ways of setting the electronic control. The following parameters can be transmitted to the RA 58:

1. Scaling factor (SCF) direct (see chapt. 0, CP no. 03) or
2. Desired number of increments per number of measured increments (see chapt. 0, CP no. 04 and 05) or
3. Desired number of increments per number of transmitter turns (see chapt. 0, CP no. 04 and 02).

Note: The SCF has to be set before the host can evaluate the data as correct actual data.

Preset: SCF = 1

HENGSTLER

3.2.1 Transmission of the Scaling Factor (SCF)

Via the SUCOnet interface of the RA 58, the SCF can be sent to the RA 58 as a 24 bit number and without operational sign. Only the digits after the point of a value below "1" will be transmitted.

After the command "Reset" (see chapter "Description of the Configuration Parameters (CP)" on page 17), the RA 58 computes with the value "1", so the position in increments determined by the RA 58 is transmitted to the host as an actual value. This value ("1") would be shown as "1 00 00 00H" in the data format with which the SCF is transmitted to the RA 58. Since only 24 bits are transmitted, the largest transmittable value is "FF FF FFH". Although this value is just below 1, the error is so small that after multiplication ($NoI \times SCF$), when the result is rounded off, it disappears.

If, for instance, the SCF is "0.5", the host has to send half of 1 00 00 00H, i.e. the value "80 00 00H" as SCF to the RA 58. The actual value put out is always half of the physical position in measured increments determined by the RA 58.

3.2.2 Setting by Driving a Measured Distance

To save yourself from computing the SCF, you can also set the electronic control of the transmitter with a "Teach in":

After a "Reset" command to the transmitter (SCF is at "1", zero offset at "0") a measured distance is driven. This determines the number of measured increments (NMI) by which the RA 58 has been moved while the measured distance was driven. Then the number of increments (NDI) desired for the measured distance is determined. After these two values have been transmitted, the RA 58 computes the appropriate SCF itself.

$$SCF = NDI/NMI$$

If the computed SCF is ≥ 1 , the RA 58 ignores it.

3.2.3 Setting by Transmitting the Resolution

The resolution of a transmitter is defined in the number of increments per number of transmitter turns. When the electronic control should be set by transmitting the resolution, it is also necessary to send 2 values to the transmitter:

Number of desired increments (NDI) which the transmitter should resolve into a number of desired turns (NoT).

$$SCF = NDI/(NoT \times MIT);$$

MIT: Measured increments per turn

MIT (RA 58) = 1024 or 4096

The necessary input values always have to be whole numbers. If, for instance, 1350 increments have been determined at 30.5 turns, both values have to be multiplied by 10 so that the input is 13500 increments at 305 T.

If the computed SCF is ≥ 1 , the RA 58 ignores it.

3.3 Zero Offset

If the physical zero point of the transmitter does not correspond to the logical zero point of the device, the zero point of the transmitter can be adjusted or shifted in accordance with the mechanical conditions of the equipment.

The formula is expanded as follows:

Actual Value = (Number of Measured increments x Scaling Factor) + Zero Offset.

Thus, the actual value is corrected after the electronic control by the zero offset. The unit of the zero offset is the same as the unit of the actual value (e.g. mm).

There are two different ways for setting the zero offset:

- Send zero offset directly to the RA 58 (see chapter 0, CP no. 07);
- Preset actual value to an absolute actual value by transmitting a preset value (see chapter 0, CP no. 01).

Preset: zero offset = "0"

3.3.1 Transmitting Zero Offset

The value of the zero offset transmitted from the host to the transmitter is added to the initial value of the electronic control. This is a 24 bit value shown in two's complements,

e.g. + 2 = 00 00 02H
 - 2 = FF FF FEH.

Example: In one of the ways described earlier, the electronic control has been initialized so that the transmitter sends the driven distance in "mm" to the host. The actual value transmitted by the RA 58 is said to be, for instance, "17438 mm", the desired set point position, however, is "15288 mm". The actual value of the RA 58 is 2150 mm too large at this point. After transmitting the zero offset "-2150 mm", the transmitter brings the correct value "15288 mm".

3.3.2 Transmitting the Preset Value

Another possibility to define the zero offset is the transmission of a preset value. In order to do this, the equipment is driven in a certain position and a desired value is transmitted to the RA 58 as preset value which the RA 58 should put out as actual value at this position. The transmitter determines internally the appropriate zero offset from the current position and the transmitted preset value. The actual value that is transmitted back at this point corresponds to the preset value.

Example: After the SCF has been set with the help of the electronic control, the equipment is driven to the position at which the RA 58 should put out the actual value 1000. This value is now sent to the RA 58 as preset value. From now on, the RA 58 puts out the value "1000" as actual value at this position.

HENGSTLER

4 Order of Transmission

When setting parameters for a RA 58, it is important to keep a certain order of transmission. This order is described in the following flow chart:

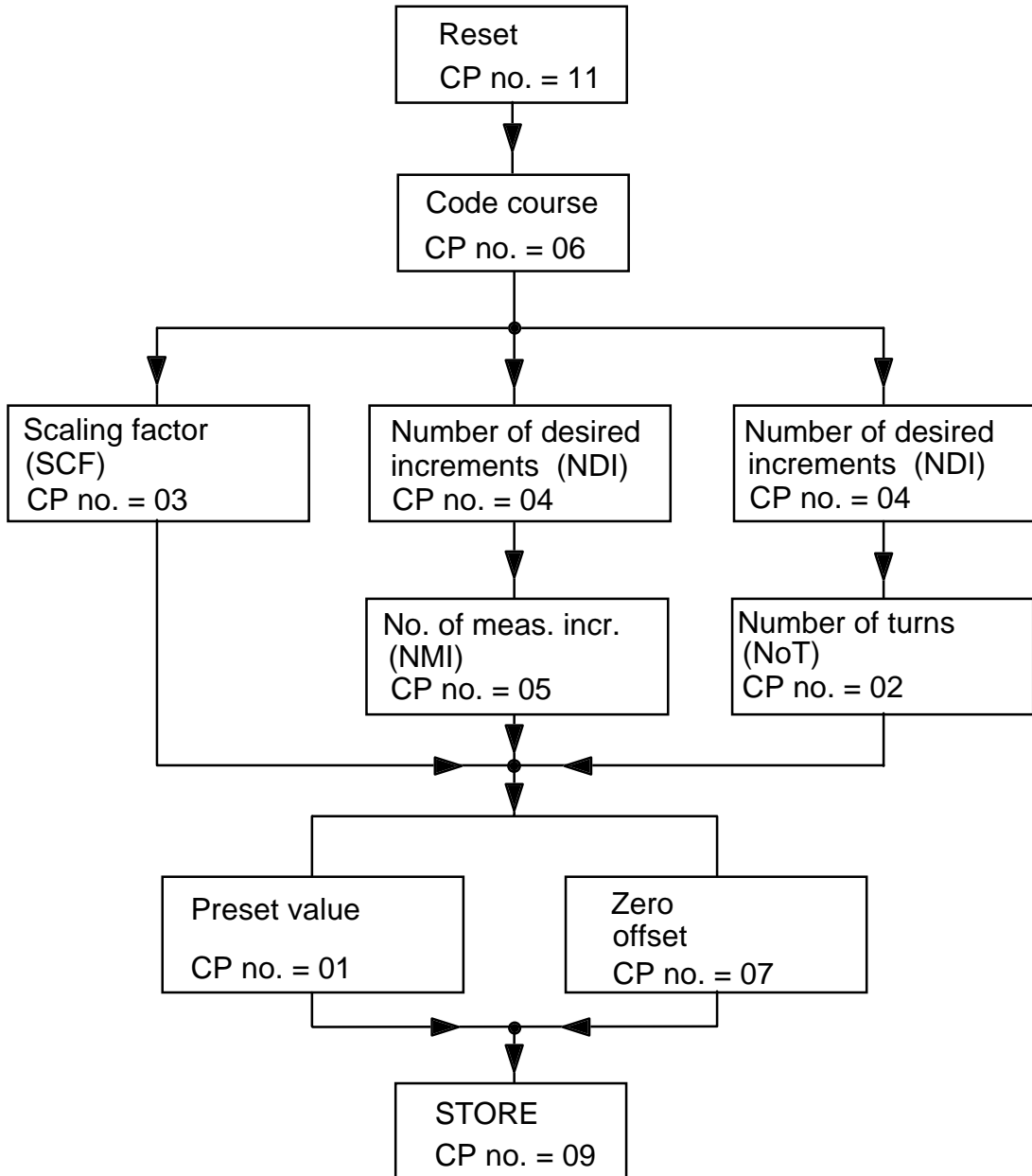

The branches located next to each other show possible alternatives, any of which can be followed.

4.1 Order of Parameter Input

1. "Reset" working storage CP no.11.
2. Code course CP no.06.
3. Scaling factor either through:
 - CP no.03 (direct input),
 - the combination CP no.04/05 or CP no.04/02.
4. Preset value CP no.01 or zero offset CP no.07 (the offsets always refer to scaled actual values).
5. "Store" working storage CP no.09; the data are stored residually. After each hardware reset, the working storage is loaded with the stored parameters.

4.2 Default Setting of the Parameters

The RA 58 has been preset to the following parameter values:

1. Preset: "0"
2. Zero offset: "0"
3. Scaling factor: "1" (maximum transmitter resolution 2^{12} or 2^{24} increments)
4. Code course: counting upwards.

HENGSTLER

5 Permanent Memory in the RA 58

To avoid losing the data transmitted by the host when turning off the power supply or in case of an unforeseen voltage loss, the RA 58 is equipped with a nonvolatile memory in form of an EEPROM.

There are two different data memories in the RA 58:

- A volatile memory as a working storage in which the CP are entered once they have been received from the host. The data contained in the volatile memory will be lost when the power supply is turned off.
- A permanent memory which keeps its data independently from the power supply.

When the CP are sent from the host to the RA 58, they are first only entered into the working storage. Once all necessary CP have been sent from the host and the transmitter delivers the actual values according to the configuration of the equipment, the contents of the working storage can be transferred to the permanent memory with a command ("Store": CP no. 09).

When the power supply is turned on, the RA 58 copies the permanent memory automatically into the working storage so that the transmitter works automatically with the data set by the host.

Copying the permanent memory into the working storage can also be commanded by the host ("Recall": CP no. 10) if, for instance, upon initial operation data have been sent to the transmitter which should be replaced by the original transmitter data.

With a command ("Reset": CP no. 11), the working storage can reset all parameters back to their preset values. In this case, the transmitter transmits the actual transmitter increments as actual value to the host. This command only presets the parameters in the working storage. If afterwards you enter the command "Recall" (as above), you will get the actual values again that were initially set and refer to the machine.

The commands "Reset" / "Store" entered one after the other reset the permanent memory so that the transmitter works with a SCF of "1", a zero offset of "0" and a code course "upwards cw".

Summary:

		Command	CP no.
Working storage	→ Permanent memory	STORE	09
Permanent memory	→ Working storage	After turning on the power supply	
Permanent memory	→ Working storage	RECALL	10
Preset values	→ Working storage	RESET	11

6 Data Transmission

6.1 Handshake between Host and RA 58

To identify the CP sent from the host to the RA 58, the individual CP are numbered. These CP numbers are located in the first byte of the telegram.

Since in most of the cases, the host runs asynchronously to the data transmission cycles, it is possible to use a software handshake between host and RA 58. For this, the CP number sent by the host is sent back in byte 6 of the reply telegram. Only when the host receives this "receipt" can new data be sent to the RA 58.

6.2 Data Traffic via SUCOnet

The data transmission takes place cyclically via an RS485 interface with 187.5 kbaud between host and RA 58. Data transmission systems with RS485 have a bus structure, i.e. all participants are connected with each other via a two-wire circuit. The data transmission to the individual participants is initiated by the host (bus master). At this time, all other bus participants are switched into receive position. Then the next bus participant is addressed etc. Each addressed bus participant sends a reply telegram.

The bus cycle time is about 2 msec if only one bus participant is connected. The bus cycle time increases accordingly with each bus participant.

The SUCOnet long protocol is used for exchanging data.

- The host transmits 6 bytes to the RA 58.
- The RA 58 sends 7 bytes to the host as reply telegram.

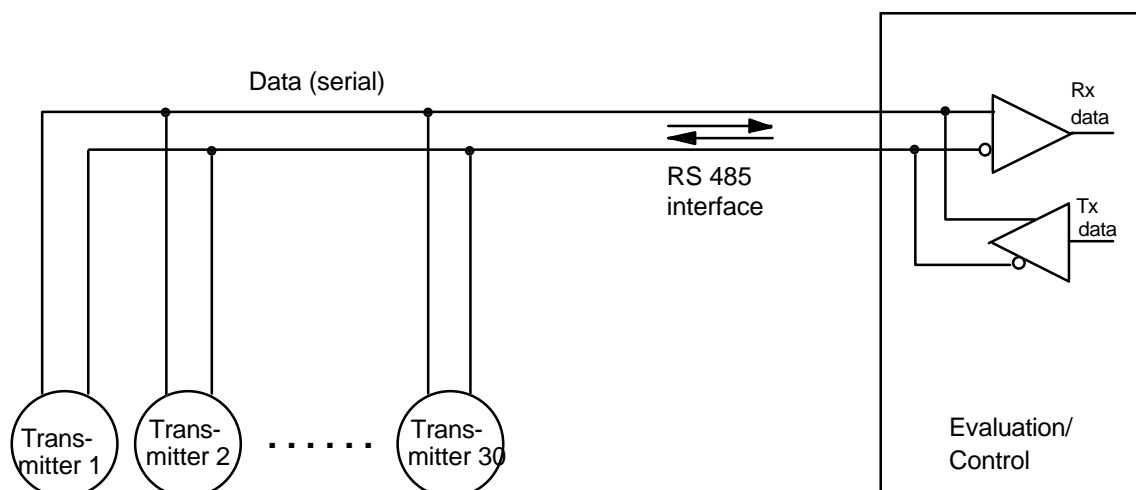

HENGSTLER

6.2.1 Meaning of the Data sent from the Host to the RA 58:

Byte no.	1	2	3	4	5	6
	CP no.	XXX	CP byte 2	XXX	CP byte 0	CP byte 1

XXX = no meaning

CP no.: The CP number indicates which kind of data the telegram is about.

The CP bytes 0 to 2 represent the transmitted configuration value (CP byte 0 = LSB).

The CP bytes 0/1 are transmitted in two's complement.

Access to the individual bytes takes place in the INL (instruction list) for the PS3, as described as follows:

Host (PS3) ⇒ RA 58 (1. slave)

Byte no.	1	2	3	4	5	6
	QB1.0	QB1.8	QA1.0	XXX	Counter Low	Counter High

The bytes 1...3 can be described in the INL by simple setting, e.g.:

```
L KB 1
= QB1.0
"
L KB 100
= QB1.8
```

For describing the bytes 5 and 6, the fast counter component has to be called up (only PS3), e.g.:

```
L KW 1000
= MW1
LN M 3.0
= M 3.0
...
C1.0
[ ] S: M 3.0
[w] I: MW1
[w] Q: MW5
...
"
```

6.2.2 Meaning of the Data sent from the RA 58 to the Host:

Byte no.	1	2	3	4	5	6	7
	RA 58 byte 0 (LSB)	RA 58 byte 1	RA 58 byte 2	XXX	XXX	CP no. echo	XXX

1. to 3. byte: Transmission of the RA 58 data (actual values)

6. byte: The CP no. transmitted by the host is sent back for handshake.

RA 58 (1. slave) ⇒ Host (PS)

Byte no.	1	2	3	4	5	6	7
	IB1.0	IB1.8	IA1.0	IA1.1	IA1.2	IA1.3	XXX

The bytes 1...6 can be read by the host with simple loading commands,
e.g.:

L IB1.0.

6.2.3 SUCOnet Telegram Bytes for PS3, PS306 and PS316

With different SUCOnet SPS, the individual bytes are addressed with different INL commands:

Master → Slave

Byte no.	PS3	PS306	PS316
1	QB1.0	QB1.0	PP192B8.0
2	QB1.8	QB1.8	PP192B8.8
3	QA1.0	PP192B9.0	PP192B9.0
4	[CStat] cannot be set	PP192B10.0	PP192B10.0
5	COUNTER LOW	PP192B11.0	PP192B11.0
6	COUNTER HIGH	PP192B11.8	PP192B11.8

HENGSTLER

Slave → Master

Byte no.	PS3	PS306	PS316
1	IB1.0	IB1.0	PP192B0.0
2	IB1.8	IB1.8	PP192B0.8
3	IA1.0	PP192B1.0	PP192B1.0
4	IA1.1	PP192B2.0	PP192B2.0
5	IA1.2	PP192B3.0	PP192B3.0
6	IA1.3	PP192B4.0	PP192B4.0
7	[CStat]	PP192B5.0	PP192B5.0

The addresses refer to a slave with the address 2

If the address is >2, 16 has to be added to the PP commands for each slave etc.
Example: Slave 3: byte no. 1: PP192B16.0

Attention: *In case of the PS306 and the PS316, the SUCOnet bus works asynchronously to the SPC program. For that reason, there needs to be a synchronization via the byte PP192B126.0 or a handshake procedure needs to be implemented if data consistency is necessary.*

6.3 Description of the Configuration Parameters (CP)

CP no. 00:

No new data to the RA 58. The RA 58 answers with the current actual value.

Byte no.	1	2	3	4	5	6
Format Dt ¹⁾	00	XXX	XXX	XXX	XXX	XXX

1) Dt = Data transmission

CP no. 01: Preset value

The preset value is a 24 bit number shown in two's complement. The zero offset in the RA 58 is set in a way that the RA 58 delivers the transmitted preset value back as actual value at the current position. The current actual value is stored in the RA 58.

Byte no.	1	2	3	4	5	6
Format Dt	01	XXX	CP byte 2	XXX	CP byte 0	CP byte 1

CP no. 02: Number of Turns (NoT)

If the scaling factor should be determined by transmission of the resolution, the following has to be sent to the transmitter:

- the desired number of increments (CP no. 04)
- and the number of turns to which the transmitter should bring the transmitted increments (CP no. 2). The take-over takes place when CP no. is changed to 02.

Maximum value: 0FFFH (=4096) T

Byte no.	1	2	3	4	5	6
Format Dt	02	XXX	XXX	XXX	CP byte 0	CP byte 1

CP no. 03: Scaling Factor (SCF)

The RA 58 data are multiplied with the SCF. The SCF is a 3 byte integer number < 1. The maximum value is FF FF FFH; this corresponds to the decimal value 0.999.... The decimal factor 0.5, for instance, corresponds to the hexadecimal value 80 00 00H, the factor 0.25 corresponds to the value 40 00 00H.

The transmission with the CP no. 03 makes it possible to enter the scaling factor directly.

Default value: 1 = (FF FF FFH)

Byte no.	1	2	3	4	5	6
Format Dt	03	XXX	CP byte 2	XXX	CP byte 0	CP byte 1

HENGSTLER

CP no. 04: Number of Desired Increments (NDI)

Transmission of the desired increments (e.g. in mm) for a driven measured distance. The value is a 3 byte integer number without operational sign. The take-over in the RA 58 takes place when the CP no. changes to 04 (flank).

The transmitted value influences the scaling factor.

Byte no.	1	2	3	4	5	6
Format Dt	04	XXX	CP byte 2	XXX	CP byte 0	CP byte 1

CP no. 05: Number of Measured Increments (NMI)

Transmission of the determined measured increments for the driven measured distance. As in no. 04, the value is a 3 byte integer number without operational sign. The take-over into the RA 58 only takes place when the CP no. is changed to 05.

The transmitted value also influences the SCF.
(The SCF is formed from the ratio: NMI/NDI)

Note: To get the maximum SCF (= "1"), two equal numbers have to be entered with the CP no. 04 and 05.

Byte no.	1	2	3	4	5	6
Format Dt	05	XXX	CP byte 2	XXX	CP byte 0	CP byte 1

CP no. 06: Code course

Counting direction upwards if LSB = 00
 Counting direction downwards if LSB = 01
 (facing the transmitter shaft, rotation clockwise)

Byte no.	1	2	3	4	5	6
Format Dt	06	XXX	XXX	XXX	CP byte 0	XXX

→ 00 = ascend. number
 01 = descend. number

CP no. 07: Zero Offset

Transmission of a zero offset. The zero offset is added to the transmitter data. This way, you can achieve the same result as with the preset value.

Difference: The desired transmitter value has to be computed.

When a zero offset is transmitted, an already set preset value is deleted.

Byte no.	1	2	3	4	5	6
Format Dt	07	XXX	CP byte 2	XXX	CP byte 0	CP byte 1

CP no. 08: Setting the Data Lengths

Byte no.	1	2	3	4	5	6
Format Dt	08	XXX	XXX	XXX	CP byte 0	XXX

↓
 10 bits
 12 bits
 22 bits
 24 bits

By sending the CP no. 08, the data length can be adjusted to the physical transmitter type.

For multiturn, a 24 or 22 bit data length can be selected, for singleturn, a 12 or 10 bit data length. **This setting is done at the factory and may not be changed.**

CP no. 09: "Store" Working Storage to Permanent Memory

When the RA 58 receives the command "Store" (data are not evaluated), the current data are transferred from the working storage to the permanent memory. The permanent memory stores these data also in case the power supply is turned off.

Byte no.	1	2	3	4	5	6
Format Dt	09	XXX	XXX	XXX	XXX	XXX

HENGSTLER

CP no. 10: "Recall" Working Storage from Permanent Memory

With the command "Recall" (data are not evaluated), the parameters stored in the permanent memory (EEPROM) are taken over to the working storage of the RA 58. After turning on the power supply, the RA 58 automatically performs the command "Recall" once, i.e. it works with the CP stored in the permanent memory without further action from the host.

Byte no.	1	2	3	4	5	6
Format Dt	0AH	XXX	XXX	XXX	XXX	XXX

CP no. 11: "Reset" Working Storage

With the command "Reset" (data are not evaluated), the working storage is deleted. Afterwards, the RA 58 works with a SCF of "1" and a zero offset of "0".

Note: All CP and the corresponding data are only stored in the memory of the RA 58 when the CP no. is changed. During normal operation, the CP no. should be set to 00.

Byte no.	1	2	3	4	5	6
Format Dt	0BH	XXX	XXX	XXX	XXX	XXX

CP no. 12: Selection of Interface

With this CP, the serial interface of the RA 58 can be reprogrammed. This CP serves to set the serial interface at the factory!

After transmission, the selected setting is automatically stored in the EEPROM. After turning the power supply off and then on again, the RA 58 works with the selected setting. Returning to the old setting is only possible by closing a switch (see chapter "Hardware Setting Options: " on page 22).

The Hengstler G1-protocol becomes valid as soon as switch 106, flip switch 6 is turned „off" (see page 22).

For SUCOnet operation, switch 106, flip switch 6 *has* to be turned „on,,.

Byte no.	1	2	3	4	5	6
Format Dt	0CH	XXX	XXX	XXX	CP byte 0	XXX



- 0 = SUCOnet, default value.
- 1 = Hengstler G1-protocol 187.5kbd.
- 2 = Hengstler G1-protocol 9600bd.
- 3 = Hengstler G1-protocol 4800bd.
- 4 = Hengstler G1-protocol 2400bd.
- 5 = Hengstler G1-protocol 19200bd.

7 Hengstler G1-Protocol

The Hengstler G1-protocol makes it possible to transfer RA 58 data to the host without large use of the software.

The G1-protocol is selected by sending the corresponding CP no.

This setting is done at the factory!

The host (SPS) sends an address word (#1H...1FH). The RA 58 addressed in this way replies with the actual value of the transmitter.

Identification of the host is done by bit 9 = "1". The RA 58 is characterized by bit 9 = "0".

Status Request:

Bit 8 in the address word serves for the status request. If this bit is "1", the RA 58 replies with a status byte. The RA 58 type and the length of the reply telegram is encoded in the LSB of the status byte:

"1" = multiturn; 4 bytes

"0" = singleturn; 2 bytes.

7.1 Bit Encoding of the Address Word

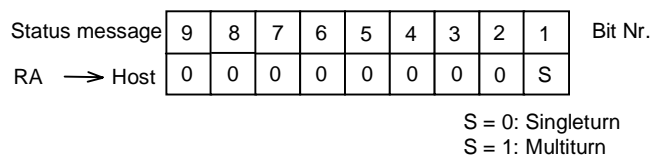
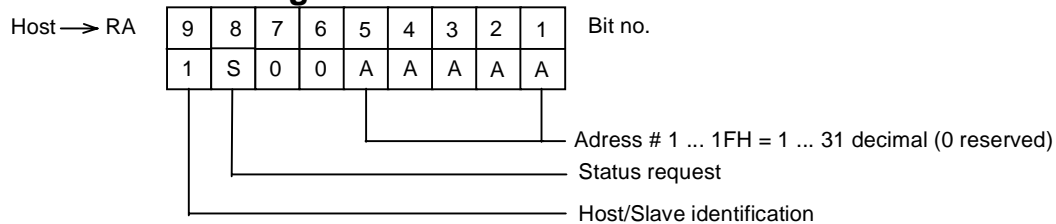

7.2 Time Response G1-Protocol

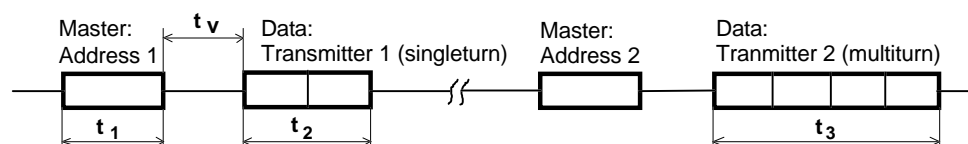

$60\mu\text{sec} < t_v < 200\mu\text{sec}$
 t_1 at 187.5KB = $55\mu\text{sec}$
 t_2 at 187.5KB = $110\mu\text{sec}$
 t_3 at 187.5KB = $220\mu\text{sec}$

HENGSTLER

8 Hardware Setting Options:

After removing the rubber stopper in the transmitter top, several switches are accessible. These can be operated with a small screw driver.

S106, switches 1 to 5: Bus address 2H ... 1FH (address 2 ... 31 decimal)
1 = LSB, 5 = MSB
Addresses 0 and 1 are occupied by the bus master
ON = 1

S106, switch 6: ON = SUCOnet mode
OFF = Hengstler G1-protocol

S106, switches 7 + 8: Switch the symmetrical bus end resistance.
If the RA 58 is the last (physical) participant at the bus, the switches 7 + 8 have to be "ON".

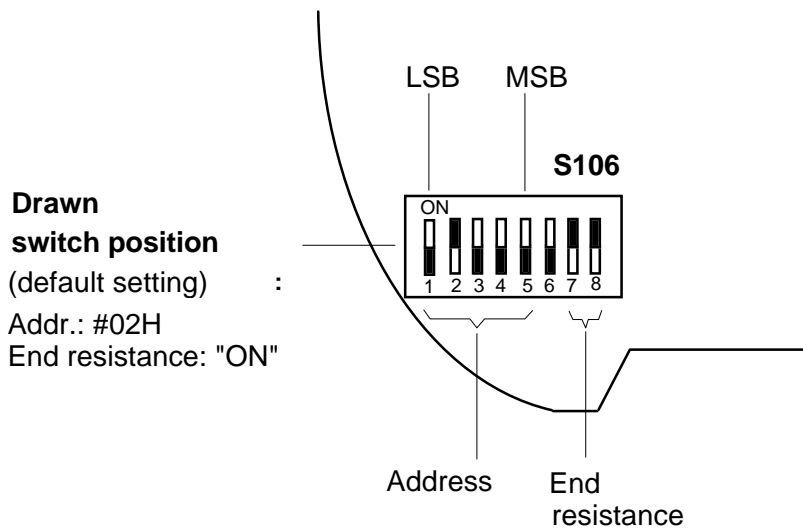

Positioning drawing from rubber stopper:

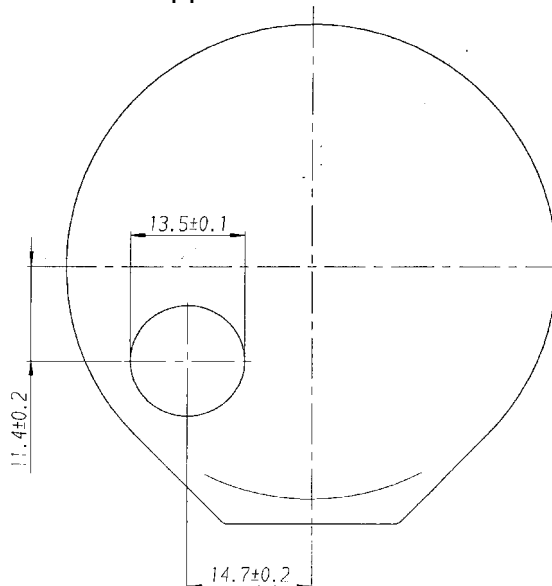

9 Initial Operation



Connect the shield on both sides to ground. The lines to the power supply also have to be completely shielded. If this is not possible, use appropriate filters.

The RA 58 is connected with the SPS and the power supply:

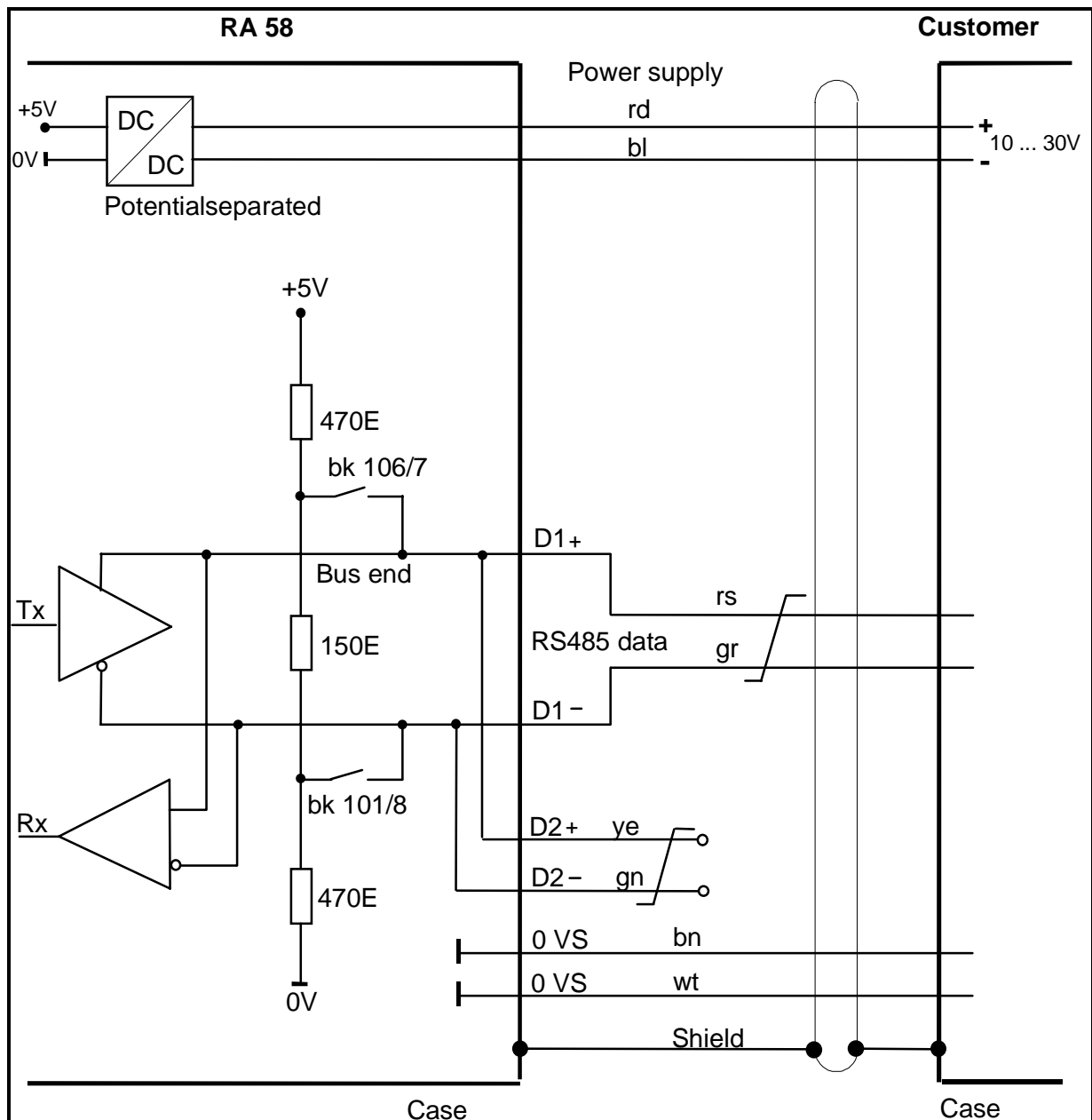

Special settings for initial operation:

Address switch on #2H; (=1. slave).

After starting the SPS with the appropriate test program, the actual values are cyclically sent to the bus master.

HENGSTLER

Test program for initial operation of a 24 bit multiturn RA 58 with the PS3:

```
L IB1.0 ;load RA 58-byte 0 (LSB)
= QB0.0 ;output at LED line
L IB1.8 ;load RA 58-byte 1
= QB1.8 ;output at LED line
L IA1.0 ;load RA 58-byte 2
= MB1.0 ;store on flag byte
EP
```

The lower 16 bits of the RA 58 actual values are put out at the LED line of the PS3.
The LED display is changed when the transmitter shaft is turned.

10 Technical Data

Mechanical:

Shaft diameter	6 mm (synchro flange), 10 mm (clamping flange)
Shaft load	axial 20 N, radial 40 N (6 mm shaft) axial 40 N, radial 60 N (10 mm shaft)
Maximum speed	10,000 rpm (short term), 6,000 rpm (continuous duty)
Torque	≤ 0.5 Ncm
Moment of inertia	synchro flange: 14 gcm ² ; clamping flange: 20 gcm ²
Protection class (EN 60529)	housing IP 65, bearing IP 64
Operating temperature	-10 ... +60°C
Storage temperature	-25 ... +85°C
Vibration resistance (IEC 68-2-6)	100 m/s ² (10 - 500 Hz)
Shock resistance (IEC 68-2-27)	1000 m/s ² (6 ms)
Connections	cable axial/radial
Housing	aluminum
Flange	S=synchro flange, K=clamping flange
Weight	multiturn 350 g approx., singleturn 300 g approx.

HENGSTLER

Electrical:

General design	according to EN 61010 part 1, class of protection III, degree of soiling 2, overvoltage category II
Power supply	10 ... 30 V DC (SELV)
Own current consumption; recommended external fuse	max. 0.2 A; T 0.25 A
EMV *	interference emission according to EN 50081-2 resistance to jamming according to EN 50082-2
Interface	RS485
Protocol	SUCOnet (K1) or Hengstler G1-protocol
SUCOnet ID **	80D0H (other device, fixed data length)
Resolution	1024 increments (10 bits) singleturn 4096 increments (12 bits) singleturn 8192 increments (13 bits) singleturn 1024 increments/4096 turns (22 bits) multiturn 4096 increments/4096 turns (24 bits) multiturn 8192 increments/4096 turns (25 bits) multiturn
Linearity	$\pm \frac{1}{2}$ LSB (± 1 LSB with resolution 13 and 25 bits)
Type of code	binary
Address switch	adjustable with 5 DIP switches (2 ... 1FH)

* in case of compliance with the shielding instructions (see chapters 0 and 0)

** used for device classification, e.g. with „System Implementation Set (SIS)“ (software from Kloeckner Moeller for SUCOnet configuration)

HENGSTLER

12 Order Code

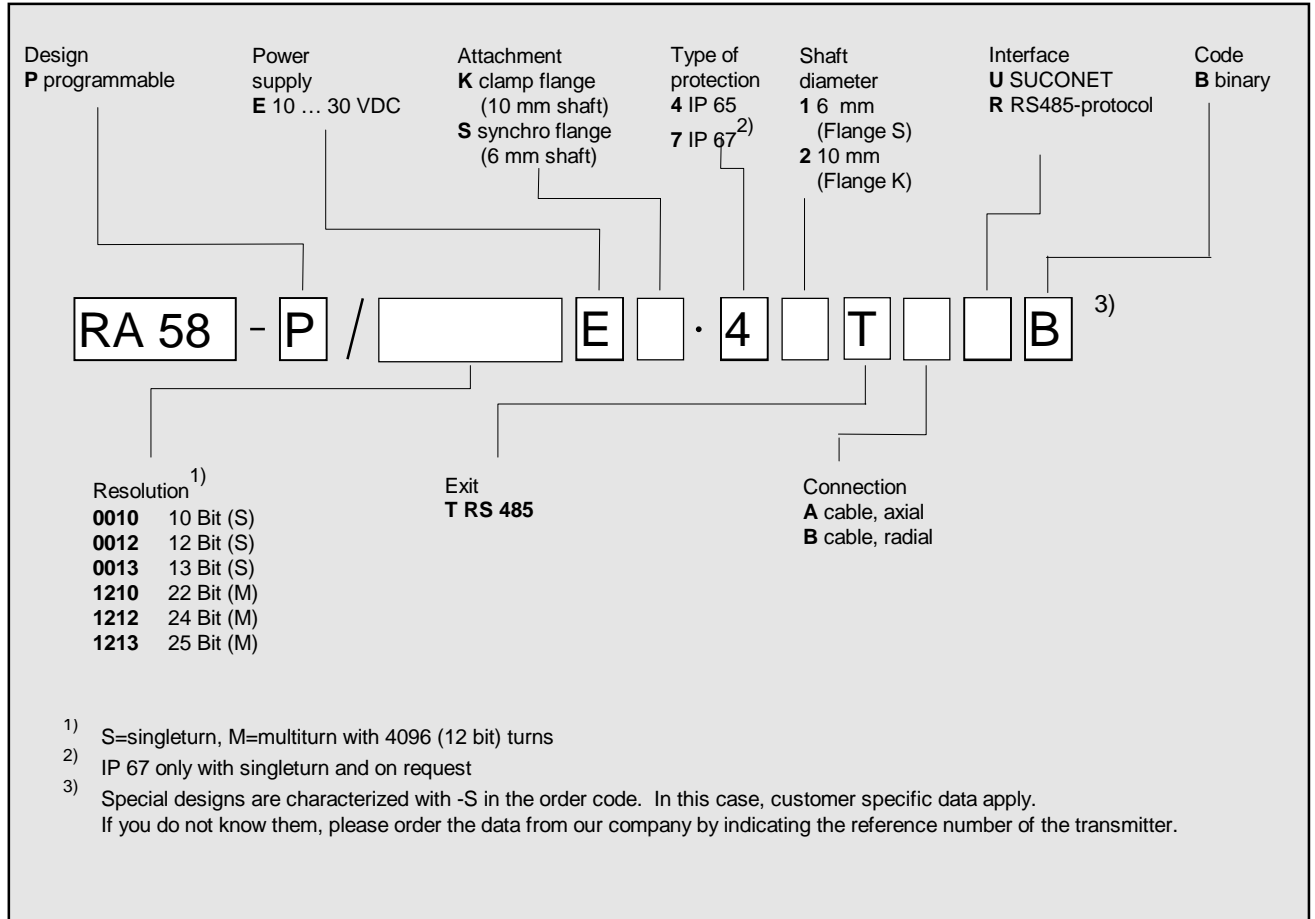

HENGSTLER

HENGSTLER GmbH
Postfach 11 51
D-78 550 Aldingen GERMANY

Phone: [+49] 74 24-8 95 39
Fax: [+49] 74 24-8 93 70
Internet: <http://www.hengstler.de>
e-mail: info@hengstler.de